



**MOLYKOTE**  
FROM DOW CORNING

Smart Lubrication™

## Food Plant Disposable Gearbox Gets 350 Percent Lifetime Increase with Food-Grade Synthetic Worm-Gear Oil

CASE HISTORY

Plant Lubricants

### Application

*Worm gear maintenance on food-processing conveyors and machinery drives at a pizza crust manufacturer.*

### Problem

*Worm gearboxes are often inaccessible, being located deep inside food-processing machinery or on overhead conveyors. This inaccessibility makes maintenance and service difficult. To minimize the need for maintenance, engineers designed disposable gearboxes that could operate for 2000 hours without any maintenance. This reduced costs related to gearbox maintenance. However, in continuous operation the throw-away gearbox required replacement every 12 weeks.*

### Product Selected

*Instead of throwing out the disposable gearboxes, this plant changed the lubricant inside to Molykote® L-1146FG Synthetic Gear Oil.*

### Results

*The expected life of the throw-away worm gearboxes increased over four times the original design, to 9000 hours. The anti-wear phosphorus-based additive in the food-grade gear oil also improved the sliding performance of the gears. The additive is non-corrosive to bronze drive components and meets food-grade requirements.*

### Molykote® L-1115FG Gear Oil – ISO150

*Lubricating your gearboxes with Molykote L-1146FG Synthetic Gear Oil is a cost-effective way to prevent premature lubricant failure and extend maintenance intervals. Unlike oils made in conventional fractionation processes, the synthetic oil is made by combining smaller molecular “building blocks” to meet targeted performance specifications and to minimize impurities. It is compatible with new-generation additives that enhance lubrication performance. The synthetic oil is formulated to reduce friction, run cooler and result in less frequent need for oil changes while providing better protection for gearbox components.*

Worm gearboxes are typically used as an inexpensive way to provide high, single-reduction gear ratios for machine drives and conveyors. These gearboxes are tolerant to start and stop operations and load variations, and are used with many types of food processing equipment. In mixers or packaging machinery, worm gearboxes are often buried inside the processing machinery. In conveyor drives, they are mounted overhead. Their inaccessibility makes it difficult to maintain and service them. The result is that often they are not well maintained, resulting in potential drive component damage and wear, and faulty motion control.

The main drive component of a worm gearbox is constructed of bronze. Extreme pressure (EP) lubricant additives that would normally enhance the sliding friction properties of the gearbox can be corrosive to bronze. This bars the use of these helpful additives in the worm gear oil formulation. The result is worm gear oil with minimal additives, having to provide all lubrication properties through high viscosity film strength.

### Disposable Gearbox

Working in partnership with a lubricant manufacturer, gearbox manufacturers identified a synthetic polyalphaolefin (PAO) lubricant that has become a standard oil for worm gears. However, the inaccessibility of the gearboxes deterred proper maintenance of the systems. To simplify maintenance requirements, one gearbox manufacturer designed a disposable gearbox filled with the standard PAO oil. The design offered maintenance personnel at food processing plants the opportunity to forego oil changes or repairs. Designed for 2000 hours of operation, the gearbox is simply thrown away after 12 weeks.

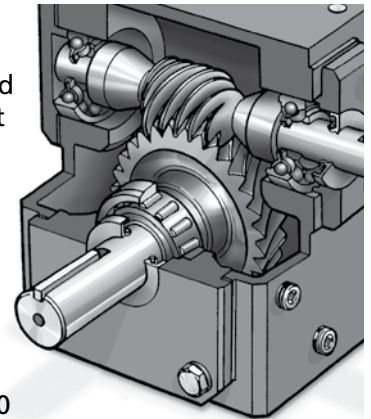

### Long-Life Food-Grade Lubricant

The standard oil change interval on the mixers, packaging machinery and conveyors was 2000 hours. To improve gear lubrication and simplify maintenance, the plant switched to Molykote® L-1146FG Synthetic Gear Oil, a Dow Corning product. Unlike oils made in conventional fractionation processes, the synthetic oil is made by combining smaller molecular “building blocks” to meet targeted performance specifications and to minimize impurities. The new oil contains a new generation phosphorus anti-wear (AW) additive to reduce friction between the gears and extend service lifetime. The formulation is non-corrosive to the bronze drive components. What is more, it is a food-grade lubricant.

Using the new synthetic oil formulation, the standard oil change interval has now been extended to 9000 hours, over four times the design life of either the conventional lubricant products or the synthetic lubricant used as OEM fill for the throw-away gearbox design.

The pizza-crust manufacturer can count on its machinery and conveyors to run for over a year before scheduling replacement of the throw-away worm gearbox. Maintenance savings in time and equipment are high, since machine uptime has increased dramatically. The PAO synthetic oil gives excellent lubrication at high and low temperatures, reduced volatility and compatibility with equipment designed for use with mineral oils. It conforms to USDA listing requirements applicable to meat and poultry plants, and is qualified for direct food contact under FDA regulations.

Molykote L-1146FG Synthetic Gear Oil maintained high lubricity even after extended exposure to the demands of the application. Friction within the gearbox was prevented to such an extent that the operating temperature during production dropped 11°C (20°F).

Molykote L-1146FG Synthetic Gear Oil offers a highly stable molecular structure. The result, when combined with the phosphorus AW additive, is a more stable lubricant that lasts longer.

Plant management adopted a policy of using only food-grade synthetic PAO products for MRO needs. Although in many cases these products exceed the unit cost of the conventional mineral oils they replace, their superior performance more than makes up for the difference. Standardizing on food-grade products eliminates the possibility that plant workers will confuse one type of oil with another.

### Benefits to the Manufacturer

- Better lubrication – food-grade gear oil is cool-running with high lubricity
- Better equipment performance
- Fewer maintenance problems
- Competitive advantage
- Reduced energy consumption

### Benefits to Food Processing Plants

- Reduce use of lubricant
- Extend interval between oil change
- Simplify record-keeping for Hazard Analysis and Critical Control Point (HACCP)
- Maintain better gearbox performance
- Extend gearbox lifetime by preventing varnish buildup
- Protect food product from contamination by non-food-grade lubricant

#### WARRANTY INFORMATION

The information contained herein is offered in good faith and is believed to be accurate. However, because conditions and methods of use of our products are beyond our control, this information should not be used in substitution for customer's tests to ensure that Dow Corning's products are safe, effective, and fully satisfactory for the intended end use. Dow Corning's sole warranty is that the product will meet the Dow Corning sales specifications in effect at the time of shipment. Your exclusive remedy for breach of such warranty is limited to refund of purchase price or replacement of any product shown to be other than as warranted. Dow Corning specifically disclaims any other express or implied warranty of fitness for a particular purpose or merchantability, unless Dow Corning provides you with a specific, duly signed endorsement of fitness for use. Dow Corning disclaims liability for any incidental or consequential damages. Suggestions of use shall not be taken as inducements to infringe any patent.

*Dow Corning* and *Molykote* are registered trademarks of Dow Corning Corporation.

*We help you invent the future.* is a trademark of Dow Corning Corporation.

©2000 Dow Corning Corporation. All rights reserved.

Printed in USA

AGP12465

Form No. 10-1001A-01

**DOW CORNING**

*We help you invent the future.*<sup>™</sup>